

# [ Spartan range ] CAST IRON

## Exclusive designs from Radiator Centre Ltd

Top quality classically styled cast iron column radiator, with integral legs in a variety of sizes and colours\*

Manufactured in Europe to achieve high quality castings.

Assembled and sprayed by hand in the UK for a high quality finish. Quality checked, Pressure tested and certified by our expert team prior to delivery.

Tested to the European standard EN 442, the Spartan is top of its range.

Available in various heights 360mm- 960mm (4 column) and 510mm or 660mm (6 column). Available in primer and colours.\*

**Outputs from 168 – 3508 watts, delivered fully assembled**

Standard Finishes:

[ Primer : RAL 7022 ]

[ Primer : White on request ]

 RAL Colour options



**7 section Sizes in stock now**

Delivery approx 3 weeks

17bar test pressure

[Image 1] Diagram

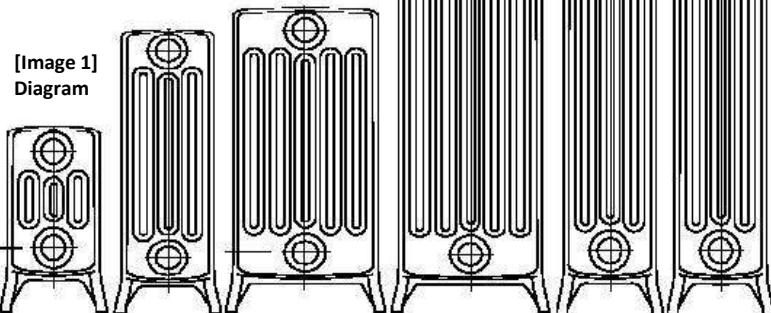

[Image 2] Detail



**Radiator Centre Ltd : 2 Grande Parade, Polegate, East Sussex, BN26 5HG**  
**www.radiatorcentre.com : info@radiatorcentre.com : Tel 01323 486848 : Fax 01323 486687**

# TECHNICAL SPECIFICATION [ Spartan range ]

This table shows single section specification. The Spartan Range can be made to any length (Max delivered length = 20 sections)

Model		36-4	51-4	66-4	81-4	96-4	51-6	66-6
Height	H1 With Foot	360	510	660	810	960	510	660
	H2 Without Foot	300	450	600	750	900	450	600
Centres	C mm	200	350	500	650	800	350	500
Section width	W mm	60	60	60	60	60	60	60
Depth	D mm	144	144	144	144	144	221	221
Water Volume per Section	litre	0.39	0.70	0.88	1.00	1.14	1.00	1.20
Dry Weight per Section*	kg	2.5	4.5	5.6	7.1	8.0	6.6	8.1
Output @ Δt 50	Watts	44	67	95	118	141	97	141
BS EN442 per sect.	Btu/hr	151	229	323	401	482	331	482
Output @ Δt 55.5	Watts	50	76	107	133	160	110	160
BS EN442 per sect.	Btu/hr	171	259	366	454	546	375	546
Output @ Δt 60	Watts	56	85	120	149	179	123	179
BS EN442 per sect.	Btu/hr	191	290	409	508	611	420	611
Maximum Factory Assembled Lengths		20	20	20	20	20	20	20

\*add 0.500kg per foot section

...\* Colours available : Matt Metallic paints (Old Penny / Natural Cast Iron / Anthracite / Black / Sovereign Gold / Antique Gold) : Any RAL Colour : Any BS Colour : Any F&B Heritage colour : "Antique" paint effects also available, POA : Standard paint finish = "Eggshell" (26-40% gloss) : Other gloss levels available on request

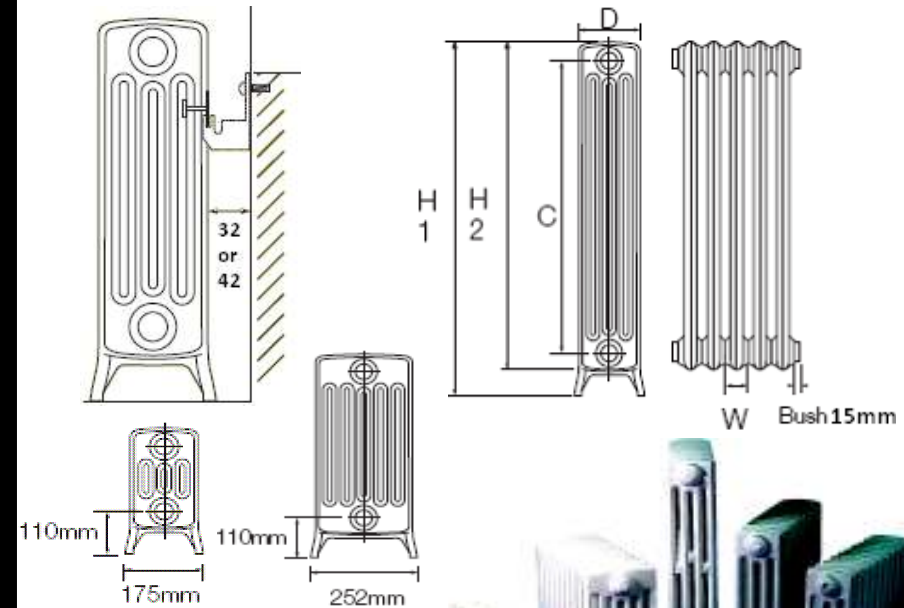

**On site assembly required for longer models**

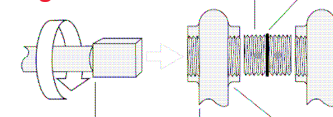

Outputs: 90/70/20 At 60c EN442